

APPLICATION NOTE

Improve Electronic Product Quality and Performance with Keysight Precision LCR Meters



Keysight E4980A, 4284A and 4285A Precision LCR Meters

Introduction

Today's intense competition in electronics dictates that products meet increased performance, quality, and cost objectives. This puts high demands on the components used, and requires increased attention to component performance and specifications.

This note describes the general application of passive component measurements in incoming inspection and R&D and shows the benefits of the Keysight Technologies, Inc. Precision LCR Meter family; the Keysight E4980A, the Keysight 4284A and the Keysight 4285A 30 MHz LCR meter with digital Q capability.

Measurements are Required Throughout the Product Process

The following passive component problems often occur in the development and manufacturing stages of electronic products:

- Although the components meet manufacturer's specifications, they exhibit different characteristics when they are integrated in a circuit.
- A part from one manufacturer substituted for that of another manufacturer shows different characteristics when it is mounted in a circuit, despite the fact that both parts are supposed to have identical specifications.
- A part that met the design values in the development department shows different characteristics on the production line.
- Increased rework costs occur when complex products fail final test due to poor component performance that could have been detected earlier in the process.

These problems are sometimes due to the fact that the test conditions of the standard specifications offered by the manufacturer do not correspond to the actual operating conditions under which the part is used. In addition, characteristics which are not covered in the specifications often influence the performance of the circuit, and may be unknowingly relied upon for proper operation.

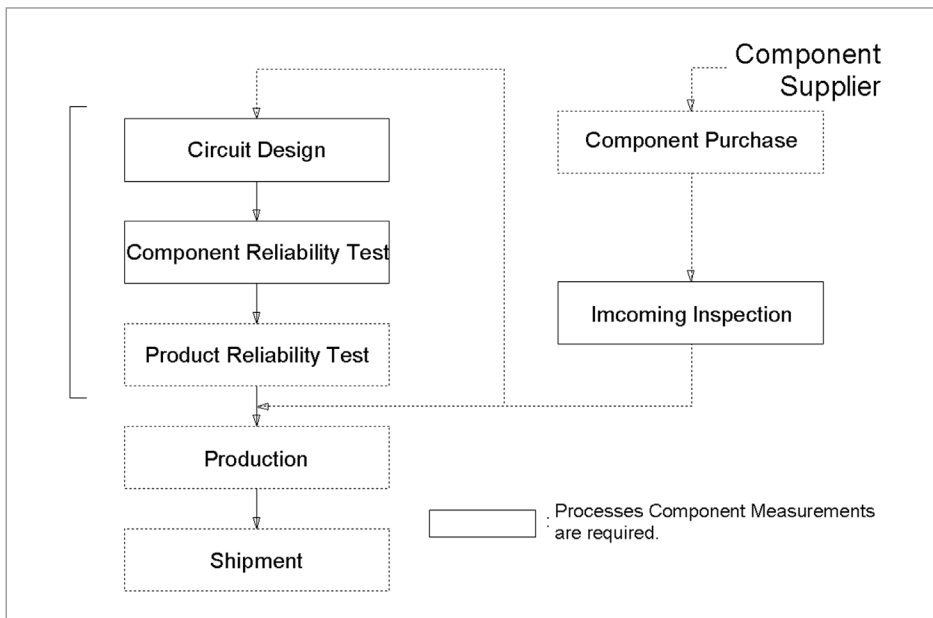

Figure 1. Component measurements are necessary throughout the design to end-product process.

The application of component measurement at two important steps of the process can eliminate many of the problems discussed. These steps, incoming inspection, and R&D are discussed below.

Incoming Inspection

The following are some of the difficulties and requirements associated with incoming inspection of passive components:

1. During incoming inspection, a great many types of measurements with a variety of measuring conditions are required:
 - As some test instruments cannot perform all of the measurements required, substitute measurements are made which may not reflect the intended specification test conditions.
 - Purchasing a large number of specialized testers for incoming inspection substantially increases capital costs.
 - Measuring instruments used in incoming inspection differ from those used by the development department. Results may not be valid for the actual operating conditions as measured in the lab.
2. Test fixtures and other factors influence the reliability of the measurements.
3. A measurement instrument should be able to measure many different types of devices, and it should respond quickly and accurately to frequently changing measurement conditions.
4. Measurement instruments of greater efficiency are required to cope with the increasing number of samples.
5. When a scanner is used, the deviation of the different channels causes discrepancies in measured values.
6. When extending the test fixture to an environmental test chamber, inaccurate measurements occur due to the cable length to the test fixture.

Conventional measurement instruments often cannot cope with these difficulties or meet the demands outlined above.

Solutions offered by the E4980A, 4284A and 4285A Precision LCR Meters for Incoming Inspection Applications

1. Precision LCR meters provide measurement flexibility that satisfies the large number of demands of incoming inspection:
 - Measurements over a wide frequency range from 20 Hz up to 30 MHz.
 - The test signal and DC bias can be set over wide ranges.
 - The Auto-Level Control (ALC) function allows measurements using constant-voltage and/or constant-current test signals.
2. High basic measurement accuracy. The E4980A and 4284A offer the highest basic accuracy of $\pm 0.05\%$ and the 4285A provides $\pm 0.1\%$ basic accuracy. Accuracy is improved by using the open/short correction function, eliminating the errors due to stray admittance and residual impedance of the test fixture.
3. A memory card facilitates setting up the instrument by storing 10 setups for easy recall.
4. An internal comparator that can be set to sort into a maximum of 10 BINS.
5. Multi-channel correction function (opt. 301) eliminates errors in individual scanner channels.
6. Cable extension function specifies measurement accuracy when the specified extension cables are used, maintaining accuracy when the test fixture is located in an environmental test chamber.
7. High throughput measurements require fast measurement times and automated handler and scanner interfaces. Precision LCR meters have exceptionally fast measurement times, as fast as 30 ms, and handler and scanner interfaces are available.

Incoming Inspection Measurement Example

Figure 4 shows the setup menu displayed on the 4284A's large liquid crystal display. The easy-to-see display facilitates setup and reduces errors.

Figure 5 shows a typical incoming inspection of capacitors using the built-in comparator. The limit value is set and distributed by bin value.

For incoming inspection applications, Keysight's Precision LCR Meters feature a wide measuring frequency range (from 20 Hz to 30 MHz) and signal sources to make measurements under actual component operating conditions. Designed for high reliability and ease of operation, these LCR meters meet the most demanding requirements of electronics manufacturers' incoming inspection departments.

Problems and Solutions in the R/D Process

Circuit design requires measurement under actual operating conditions

To design a high quality circuit, the characteristics of its components under actual operating conditions must be known. That is, the characteristics of components depend on the conditions (frequency, signal level, temperature, etc.) under which they are used or measured. In most cases, due to the inflexibility of the measurement system, the conditions under which components are tested and selected are different from the conditions the components will see in actual operation.

```

<BIN COUNT DISPLAY>      SYS MENU
FUNC : Cp-D              NOM : 115.000pF
BIN  LOW [ % ]  HIGH [ % ] >COUNT
1  -  1.000  +  1.000      2463
2  -  2.000  +  2.000      652
3  -  3.000  +  3.000      251
4  -  4.000  +  4.000      106
5  -  5.000  +  5.000       36
6  -  -  -  -  -  -  -  -  0
7  -  -  -  -  -  -  -  -  0
8  -  -  -  -  -  -  -  -  0
9  -  -  -  -  -  -  -  -  0
2nd REJ CNT  AUX: OFF      OUT: [ 13 ]
    
```

Figure 2. The Bin Count Display shows results of automatic component selection using the internal comparator.

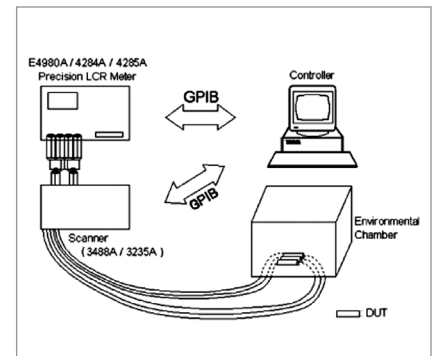

Figure 3. Accurate measurements with the test fixture extended from the LCR meter are provided with the cable extension function.

```

<MEAS SETUP>            SYS MENU
FUNC : Cp-D              RANGE:  AUTO
FREQ : 1.00000kHz       BIAS :  0.000 V
LEVEL : 1.00 V          INTEG :  MED

TRIG :  INT              AVG :    1
ALC   :  OFF             Vm  :    ON
Hi-PW:  OFF              Im  :    ON
DELAY :    0ms

DEV A : OFF              REF A : 0.00000 F
      B : OFF              REF B : 0.00000
    
```

Figure 4. Large LCD screen shows the setup menu for the test.

```

<BIN No. DISPLAY>      SYS MENU
FUNC : Lp-D              RANGE:  AUTO
FREQ : 1.00000kHz       BIAS :  0.000 V
LEVEL : 1.00mA          INTEG :  MED
                        COMP :  ON

      B I N  1

      LP : 175.926mH      D : .261900
      CORR: OPEN,SHORT
    
```

Figure 5. Measurement result using the built-in comparator.

In the next example, a VCO circuit, the measurement of a critical inductor was key in making the circuit meet performance specifications. Knowing the Q of the inductor at actual operating conditions allowed the proper component to be specified to meet the overall phase noise specification of the circuit.

This VCO circuit was designed as a part of a frequency synthesizer circuit with a frequency range of 20 Hz to 30 MHz. The design specification called for the phase noise measured at a 1 kHz offset to be less than -110 dBc/Hz at an output frequency of 30 MHz.

The first-pass design used a 1μH inductor (L1) selected for a high Q value at 7.96 MHz, the traditional test frequency used by older Q measuring equipment. The measured Q was 43 at 7.96 MHz. The phase noise was then measured with the results being -107 dBc/Hz at 30 MHz, out of spec. Knowing that the Q of the circuit affects the phase noise, the designer investigated the variation of the Q of L1 as a function of frequency using the 4285A Precision LCR Meter that can measure inductors to 30 MHz. Using the List Sweep feature, measurements were performed quickly and easily at a number of test frequencies. See Figure 7.

The reason for the poor phase noise performance at 30 MHz was the Q of L1 was only 25 at 30 MHz. The Keysight 4285A was then used to select another inductor, making the Q measurement at 30 MHz instead of 7.96 MHz. An inductor with a Q of 60 at 30 MHz was selected. The phase noise at 1 kHz offset was measured again with the results being -112 dBc/Hz. Figure 8 shows the phase noise results with the two inductors selected. Characterizing passive components at actual operating conditions provides important insight to the design performance, and should be standard operating procedure for design and component evaluation in the R&D phase of electronic product design.

Sometimes the component's performance is tested in R&D in environmental test chambers. This requires that the test fixture is remote from the test equipment. For LCR measurements above 100 kHz, cable capacitance unbalances the measurement bridge circuit, causing errors.

Keysight's Precision LCR meters have cable extension features that specify the measurement accuracy at the remote location, when specified cables are used. In addition open and short correction calibration can be performed at the end of the extension cables for increased accuracy.

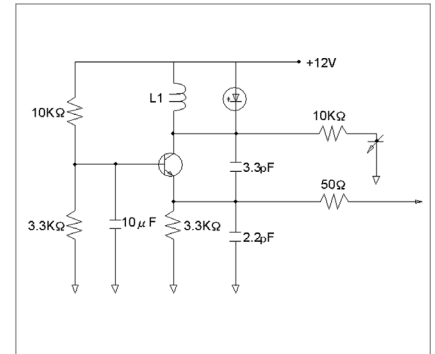

Figure 6. Part of VCO circuit used in a 20 Hz to 30 MHz synthesizer.

```
<LIST SWEEP DISPLAY>   SYS MENU
MODE : SEQ
FREQ [Hz]  LS [ H ]    Q [ ]  CMP
100 . 0k   964 . 218n          6 . 38
1 . 0000M  952 . 029n         21 . 0
5 . 0000M  949 . 875n         39 . 9
7 . 9600M  950 . 848n         42 . 7
10 . 0000M 953 . 947n         40 . 8
20 . 0000M 960 . 966n         31 . 0
30 . 0000M 968 . 361n         24 . 2
```

Figure 7. Ls and Qs Frequency characteristics of a 1μH inductor used in the firstpass VCO design. Note Q drop-off at 30 MHz.

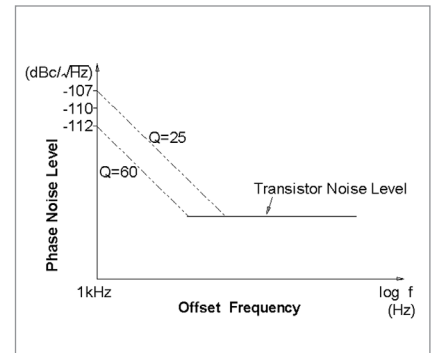

Figure 8. Improved phase noise resulted from using a high Q inductor, selected by measuring the Q at 30MHz with a 4285A Precision LCR Meter.

Conclusion

Throughout the product design to final manufacture cycle, understanding the performance of the components used is critical to meeting performance, cost, and reliability goals. Test equipment must be flexible to test the components at many different operating conditions to simulate the actual circuit situations. For incoming inspection, high throughput and fast changeover to different setups is critical, while in R&D measurement flexibility and performance is important to fully understand the component parameters that affect design quality.

Keysight's Precision LCR Meters are designed to meet the most demanding R&D requirements while offering high throughput, handler, and scanner interfaces, and system integration features for incoming inspection applications.

For more information on how Keysight's component test products can help you design, test, and produce quality electronic designs, contact your local Test and Measurement Sales Representative.

Learn more at: www.keysight.com

For more information on Keysight Technologies' products, applications or services, please contact your local Keysight office. The complete list is available at: www.keysight.com/find/contactus

